

Operating Instructions

Displacement sensor CD3 series

Laser type

Thank you for purchasing the CD3 series sensor. Please verify that the specifications are applicable for your application.
Please read this manual thoroughly before using the sensor, and retain it for future reference.

1 Specifications

		Laser Type				
Type	Cable Type	CD3-30 (N,P)	CD3-50 (N,P)	CD3-80 (N,P)	CD3-100 (N,P)	CD3-250 (N,P)
	Connector Type	CD3-30C (N,P)	CD3-50C (N,P)	CD3-80C (N,P)	CD3-100C (N,P)	CD3-250C (N,P)
Measuring Range		30 +/- 4 mm	50 +/- 10 mm	80 +/- 15 mm	100 +/- 40 mm	250 +/- 150 mm
Light Source		Class 2 Red Laser Diode (wavelength 650 nm)				
Peak Power		1 mW max.				
Pulse Length		300 μsec.				
Pulse Repetition Rate		1 kHz				
Frequency		1 kHz				
Spot Size (center of range)		∅ 0.5 mm	∅ 0.8 mm	1 x 1.5 mm	1 x 1.5 mm	3 x 1.5 mm
Supply Voltage		12 ~ 24 VDC (-5%, +10%)				
Current Consumption		120 mA max. / 12 VDC, 80 mA max. / 24 VDC Including the analog output value				
Resolution *1		4 μm	10 μm	10 μm	30 μm	150 μm
Linearity *2		+/- 1% F.S.				≥250mm: +/-1.5%F.S. <250mm: +/-2.5%F.S.
Temperature Drift		+/- 0.08% F.S. / °C				
Response Time		2.2 msec. max. (Sensitivity: fixed, averaging: 1) 22.5 msec. max. (Sensitivity: AUTO, averaging: 1)				
Outputs	Analog Output	4 ~ 20 mA				
	Switching Output	NPN / PNP Transistor 100 mA max. / 24 VDC Residual voltage 1.8 V max.				
Indicators	Distance Indicator	Near	: Red			
		Middle	: Orange			
		Far	: Green			
Out of range		: Blinking Red/Green				
Reflection too high / low		: Blinking Red/Green				
Stability Indicator	Stable	: Green				
	Unstable	: Indicator OFF				
	Reflection too high / low	: Red				
Output Indicator	ON status	: Orange				
Ambient Light		Sunlight: 10,000 lux max. Incandescent lamp: 3,000 lux max.				
Operating Temperature		-10° ~ +40° C				
Operating Humidity		35 ~ 85% RH				
Housing Material		Zinc die-cast				
Protection Category		IP67				
Weight	Cable Type	Approx. 130g (without cable)				
	Connector Type	Approx. 140g				

F.S. (Full scale) is defined as, CD3-30: 8 mm, CD3-50: 20 mm, CD3-80: 30 mm, CD3-100: 80 mm, CD3-250: 300 mm

*1 Center of measuring range, Sensitivity: AUTO, Averaging: 64, Object: White ceramic

*2 Linearity error (Sensitivity: AUTO, Averaging : 64, Object: White ceramic)

2 Connection diagram

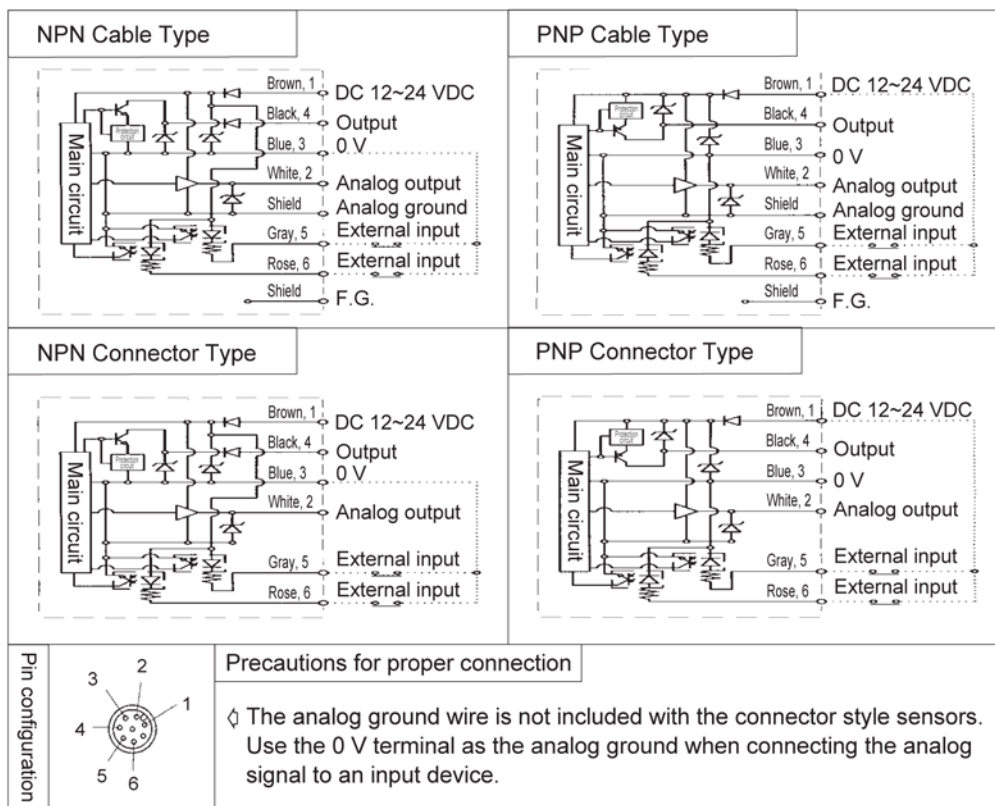

- 1) Connect the lead wires correctly. The analog output wire must not come in contact with any other wires. Verify that the power supply is OFF while connecting the sensor.
- 2) The Blue wire (0 V) and the Shield wire (Analog ground) are internally connected. Use the Blue wire (0 V) for the power supply connection and use the Shield wire (Analog Gnd) for the analog output.

3 Installation

Install the sensor and adjust the distance of the sensor to the desired measuring point so that the distance indicator turns ON (Orange) indicating that it is in the center of the measuring range.

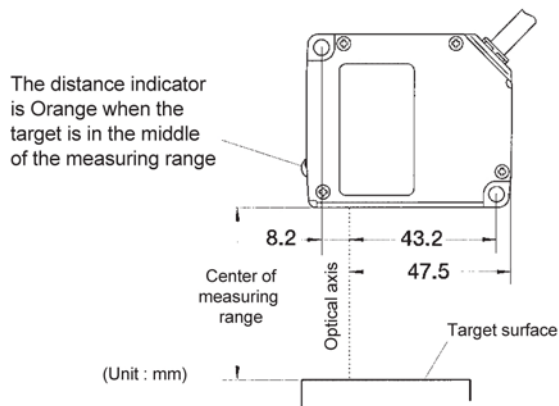

- ⚠ Adjust the sensor position so that the optical plane of the sensor is parallel with the plane of the target to be detected to insure reliable measurement.
- ⚠ In the laser type sensor, there is an invisible circle of light around the visible projected light spot. If there is any material around the detection area that is glossier than the target this could lead to incorrect measurement.

4 Functions of components

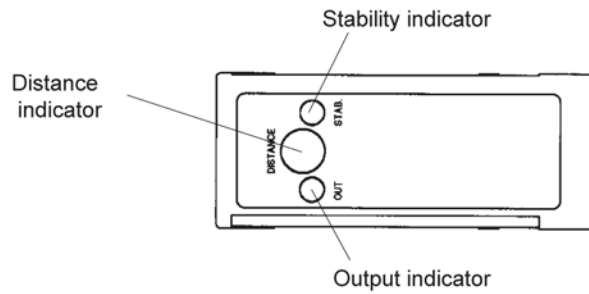

Distance Indicator	<p>This LED indicates the distance from the sensor to the target.</p> <p>◇ The LED will flash Red and Green when the Stability indicator is red due the reflection level being too High or Low.</p>
Stability Indicator	<p>This LED indicates the level of received light intensity.</p> <p>GREEN : Stable measurement OFF : Unstable measurement RED : Measurement is impossible due the receiving light level being too high or low.</p>
Output Indicator	<p>Orange : Transistor output is ON OFF : Transistor output is OFF</p>

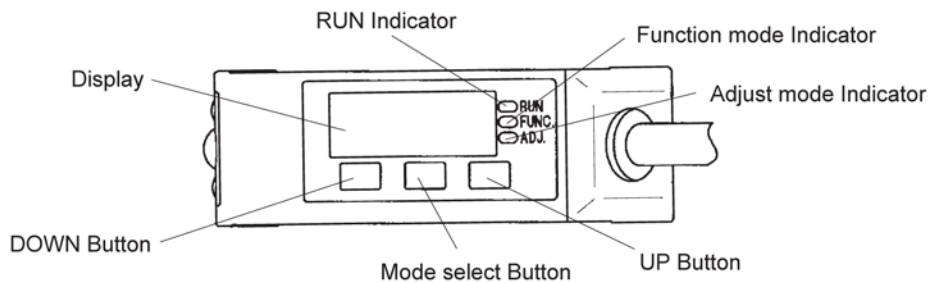

RUN Indicator	This LED indicates the sensor is in the RUN mode.
Function Mode Indicator	This LED indicates the sensor is in the function select mode.
Adjust Mode Indicator	This LED indicates the sensor is in the adjust mode.
Display	<p>RUN indicator ON : Indicates the distance from the sensor to the target. Function mode indicator ON : Indicates the function. Adjust mode indicator ON : Indicates the value of the selected function.</p>
Mode Select Button	<p>The MODE is changed by using this button.</p> <p>T = time duration while pressing the button</p>
Up / Down Button	<p>RUN mode : No effect Function select mode : Select function Adjust mode : Adjust the value of the function</p>

5 Functions

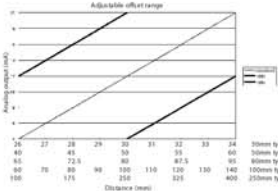
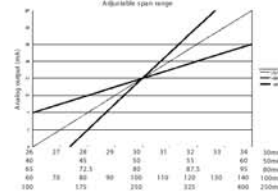
Function	Display Indication	Adjust Mode Indication	Adjust / Select Item	Initial Value																																													
Upper Switching Level	High	4.00 ... 20.00 (mA) Current indication/Indication off -9999 ... 9999 Relative distance -4.00 ... 4.00 (mm) 30 mm type, distance indication -10.00 ... 10.00 (mm) 50 mm type, distance indication -15.00 ... 15.00 (mm) 80 mm type, distance indication -40.00 ... 40.00 (mm) 100 mm type, distance indication -150.00 ... 150.00 (mm) 250 mm type, distance indication	The upper switching level can be adjusted.	Center of measuring range + 5% F.S.																																													
Lower Switching Level	Lo	Same as above	Same as above	The lower switching level can be adjusted.	Center of meas. range - 5% F.S.																																												
Output type (Timer)	OtyP	only, oFdy, onEs, oFF	The operation mode of the Timer is selected. only : On delay oFdy : Off delay onEs : One shot oFF : No timer function	oFF																																													
Timer period	tlEr	0 ... 999 (ms), 1_S ... 10_S	The timer period can be adjusted 0 ... 999 ms : 1 ms increments - 1 ... 10S : 1 second increments	0																																													
Hysteresis	Hyst	0.00 ... 1.99 (mA) Current indication/Indication off 0000 ... 2499 Relative distance 0.00 ... 1.00 (mm) 30 mm type, distance indication 0.00 ... 2.49 (mm) 50 mm type, distance indication 0.00 ... 3.75 (mm) 80 mm type, distance indication 0.00 ... 10.00 (mm) 100 mm type, distance indication 0.00 ... 37.50 (mm) 250 mm type, distance indication	The hysteresis of the output can be adjusted.	0.15% F.S.																																													
Averaging	Arg	1, 4, 16, 64, 256, 1024	The number of readings to average together can be selected.	64																																													
Sensitivity	SEnS	1 ... 20, AUTO	The Sensitivity can be selected. 1 (low) ~ 20 (high) : The sensitivity is fixed at the set level. AUTO : The sensitivity will be automatically adjusted.	AUTO																																													
Offset	OFSt	-50.0P ... 50.0P	The analog output can be offset +/- 50% from the initial value. 	0.0P																																													
Span	SPAn	-50.0P ... 50.0P	The span of the analog output can be adjusted +/- 50% from the initial value. 	0P																																													
Analog output when reflection is too high/low	EoUT	Hold, CLp	What the analog value is to do when the reflection is too high/low. Hold : The analog output is held at the value it was immediately prior to the reflection becoming too high / low. CLp : The analog value is fixed at 24 mA.	CLp																																													
Display type when in RUN	dISP	4-20, dlSt, 0-99, off, rdls	The type of information to display during RUN is selected. 4 ~ 20 : This is the value of the analog output. dlSt : Distance indication (mm) -4.000 ... 4.000 30 mm type -10.00, -9.999 ... 9.999, 10.00 50 mm type -15.00 ... -10.00, -9.999 ... 9.999, 10.00 ... 15.00 80 mm type -40.00 ... -10.00, -9.999 ... 9.999, 10.00 ... 40.00 100 mm type -150.0 ... -100.0, -99.99 ... 99.99, 100.0 ... 150.0 250 mm type 0 - 99 : Relative distance within the range (-9999~9999) off : Display off rdls : Reverse the plus / minus when distance is displayed.	dlSt																																													
Bank	Ban	0, 1, 2, 3	Four sets of parameters can be stored in the sensor. *1	0																																													
External input type selection	InPt	A Type A b Type B c Type C d Type D	The operation of the two external input wires (Rose and Gray) can be configured to four different modes. Type A (bank select) <table border="1" data-bbox="1031 1606 1421 1669"> <tr><td>Bank No.</td><td>0</td><td>1</td><td>2</td><td>3</td></tr> <tr><td>Rose wire</td><td>OFF</td><td>ON</td><td>OFF</td><td>ON</td></tr> <tr><td>Gray wire</td><td>OFF</td><td>OFF</td><td>ON</td><td>ON</td></tr> </table> Type B <table border="1" data-bbox="1031 1675 1421 1717"> <tr><td>Rose wire</td><td colspan="4">Laser off</td></tr> <tr><td>Gray wire</td><td colspan="4">Reset</td></tr> </table> Type C <table border="1" data-bbox="1031 1724 1421 1766"> <tr><td>Rose wire</td><td colspan="4">Sensitivity teaching</td></tr> <tr><td>Gray wire</td><td colspan="4">Reset</td></tr> </table> Type D <table border="1" data-bbox="1031 1772 1421 1814"> <tr><td>Rose wire</td><td colspan="4">Laser off</td></tr> <tr><td>Gray wire</td><td colspan="4">Sensitivity teaching</td></tr> </table> ON : PNP type is connected to +V and NPN type is connected to 0V.	Bank No.	0	1	2	3	Rose wire	OFF	ON	OFF	ON	Gray wire	OFF	OFF	ON	ON	Rose wire	Laser off				Gray wire	Reset				Rose wire	Sensitivity teaching				Gray wire	Reset				Rose wire	Laser off				Gray wire	Sensitivity teaching				A
Bank No.	0	1	2	3																																													
Rose wire	OFF	ON	OFF	ON																																													
Gray wire	OFF	OFF	ON	ON																																													
Rose wire	Laser off																																																
Gray wire	Reset																																																
Rose wire	Sensitivity teaching																																																
Gray wire	Reset																																																
Rose wire	Laser off																																																
Gray wire	Sensitivity teaching																																																
Internal memory ON / OFF	EEP	On, OFF	1. Choose OFF if you do not wish to write the settings into the internal memory. 2. Choose OFF to extend the overall life of the internal memory. The memory is limited to approx. 100,000 write operations. * Each time the data is changed with the buttons it is written into memory. Information that is not stored in memory will be lost when the power is turned off.	On																																													

*1 The settings for InPt and EEP are not stored in the banks.

6 Adjust / Select Functions

1. Press and hold the Mode Select button for more than 3 seconds.
The Function Select Mode will become active. The current function that can be adjusted will be displayed.

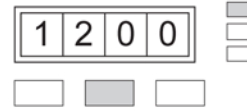

2. Use the UP / DOWN buttons to select the desired function.

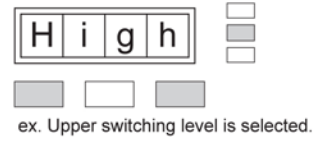

3. Press the Mode Select button momentarily (less than 3 seconds).
The value of the selected function will be displayed.

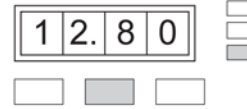

4. Use the UP / DOWN buttons to change the setting.

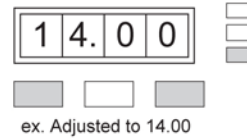

5. Press and hold the Mode Select button for more than 3 seconds.



Return to the RUN mode.

- Press and hold the Mode Select button for less than 3 seconds.



Return to the function select mode. (additional functions can be adjusted).



↶ Restore Default Settings

Press and hold the Mode Select button while turning on the power.
All values will be restored to the original default settings.

7 Teaching

The switching level, sensitivity and offset are adjusted by teaching.

1. Press and hold the Mode Select button for more than 3 seconds.
The Function Select Mode will become active. The current function that can be adjusted will be displayed.

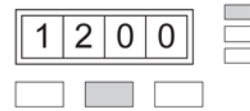

2. Use the UP / DOWN buttons to select the desired function.

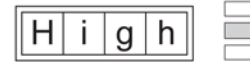

ex. Upper switching level is selected.



3. Press the Mode Select button momentarily (less than 3 seconds).
The value of the selected function will be displayed.

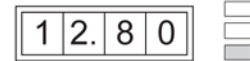

4. Place the target at the desired distance and press the UP / DOWN buttons at the same time.

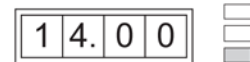

Press simultaneously



5. The display will flash the new value 3 times, teaching is complete.

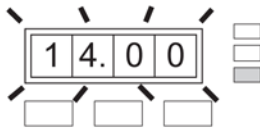

Flash 3 times

If an error is indicated, verify the position is correct and all conditions are within spec.

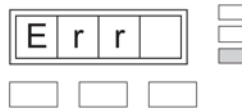

5. Press and hold the Mode Select button for more than 3 seconds.



Return to the RUN mode.

- Press and hold the Mode Select button for less than 3 seconds.



Return to the function select mode. (additional functions can be taught).

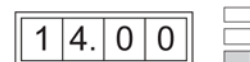

8 Warnings and Precautions

Warnings

◇ Laser beam

This item utilizes a visible light laser as the light source and is subject to safety standard Class 2 of JIS C6802 as well as IEC and FDA regulations.

DO NOT stare into the beam, or reflect the beam with a mirror.

DO NOT disassemble the unit. The sensor is not equipped with an auto-laser-off function.

Precautions

◇ DO NOT allow dust, oil, water, etc. to accumulate on the sensor face.

It will degrade the sensor operation. If necessary wipe the face of the sensor with a dry cloth to remove contamination.

◇ When a switching regulator is to be used as the power supply, be sure to connect the frame ground to the ground terminal.

◇ DO NOT use the sensor in a transient state at power up (Approx. 30 min. warm-up time).

◇ DO NOT run the sensor cable near any high-voltage or power lines nor put them together in the same raceway. This warning should be strictly observed to prevent malfunctions caused by inductive interference.

◇ Use of controls or adjustments or performance of procedures other than those specified herein may result in hazardous radiation exposure.

◇ Sensors equipped on machinery are under FDA of American laser regulation. The CD3 series has already been registered with the CDRH (Center for Devices and Radiological Health)

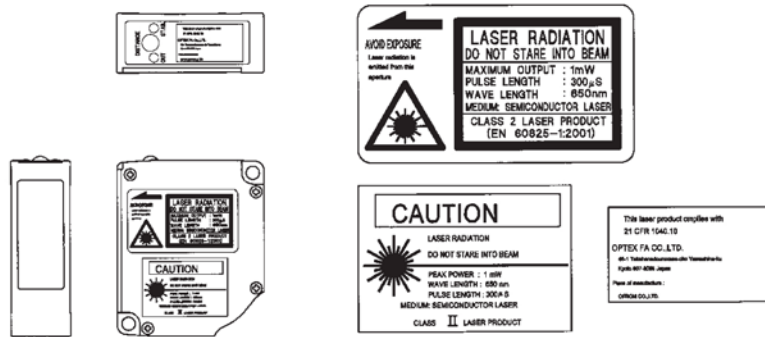

⚠ DO NOT use this item as safety equipment for the purpose of human body protection.

9 Dimensional drawing

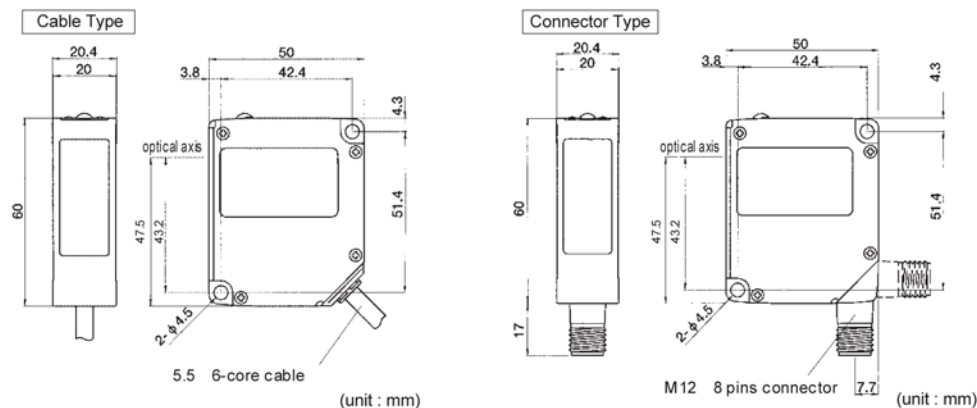

Developed by
OPTEX FA CO., LTD.



OPTEX FA CO., LTD.