

INSTRUCTION MANUAL

V2-SERIES SMALL BGS SERIES PHOTOELECTRIC SENSOR AC/DC: Relay output DC: transistor output

- Thank you for purchasing V2 series and small BGS-series photoelectric sensor. Check that the specifications agree with yours.
- Please read this manual through before using the sensor, and retain it for future reference.

SPECIFICATIONS

	V2 series AC/DC type					V2 series DC type					Small BGS series	
	Through beam	Retro-reflection (Polarizing filter)	BGS			Through beam	Retro-reflection (Polarizing filter)	BGS			Long range	Short range
			Long range	Middle range	Short range			Long range	Middle range	Short range		
Cable type	V 2 T-2000	V 2 R-800	BGS-V80	BGS-V50	BGS-V30	V 2 T-2000D ^N	V 2 R-800D ^N	BGS-V80 ^N	BGS-V50 ^N	BGS-V30 ^N	BGS-30 ^N	BGS-10 ^N
Connector type	—	—	—	—	—	V 2 T-2000CD ^N	V 2 R-800CD ^N	BGS-V80CP	BGS-V50C ^N	BGS-V30C ^N	BGS-30C ^N	BGS-10C ^N
Detecting distance	20m	8 m	25~80cm	15~50cm	10~30cm	20m	8 m	25~80cm	15~50cm	10~30cm	10~30cm	4 ~10cm
Supply voltage	DC12~240V ±10% AC24~240V ±10% 50/60Hz					DC10~30V						
Current consumption	3 VA max.					35mA max.	30mA max.			25mA max.		
Response time	15ms max.					1 ms max.	0.7ms max.	3 ms max.			2 ms max.	
Hysteresis	—		20%max.	5 %max.		—		15%max.			5 %max.	
Light source	Red LED											
Sensitivity adjustment	2 rotation volume					—		2 rotation volume				
Indicator	LIGHT Indicator (Red)											
Operation mode	Light ON					Light ON/Dark ON selectable by wiring						
Control output	Relay1C DC30V 2A/AC250V 0.3A max.					NPN/PNP open collector DC30V 100mA max.						
Ambient temperature humidity	-25~55°C / 35~85%RH											
Environmental illuminance	Sun light : 10000lx max. Incandescent light : 3000lx max.											
Protection category material	IP67 (IEC 144) / Case : ABS (Glass fiber included) Front cover : PC (PMMA for retro-ref.type)											

● Adjusting the optical axis.

○ Through-beam type

1. Install the emitter and the receiver opposite to each other so that the optical axis lines up.
2. Swing the emitter and the receiver vertically and from side to side, and fix each at the mid-point in the range where the indicating lamp at the receiver lights up.

○ Reflection type

Swing the sensor vertically and from side to side, and fix it at the mid-point in the range where the indicating lamp lights up.

● Adjusting the sensitivity control

1. Set the detectable object at the detection position and turn the sensitivity control slowly from MIN toward MAX until the indicating lamp lights up. Call it position A.

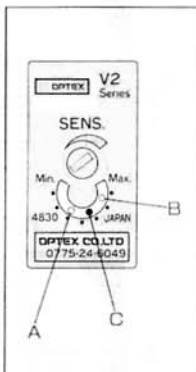

2. Remove detectable object and turn the sensitivity control from MAX toward MIN position where the indicating lamp is extinguished. Call it position B.
3. Point C midway between A and B is the optimum sensitivity position.

● TEST INPUT function

(Available only in DC type Emitter)

When the Test input wire is connected to OV, an interrupted status is electrically invented by stoppage of emission. This function can be used as on operational check of the sensor by electric interrupted state without detectable object.

● BGS performance

BGS types give stable sensing regardless of colors on objects. Technical details is referred in the catalogue.

● Other precautions

- Be careful not to install the sensor at the following locations, for it may otherwise malfunction :
 - Where a lot of dust, vapor, or the like is present
 - Where corrosive gases are produced
 - Where water, oil or the like flies directly onto the sensor.
 - Where strong vibration or shock is caused to the sensor.
- Do not use organic solvent, such as thinner, to remove contaminants from the body case, lid and lens which are all of plastics. Using a dry rag, just wipe clean.
- When a switching regulator is to be used with a power supply, be sure to ground the frame ground terminal
- Avoid wiring together with high voltage or motor line in order to prevent the sensor form noise.
- Do not use the sensor in a transient state at power on. (about 150 ms)

DIMENSIONS

(Unit : mm)

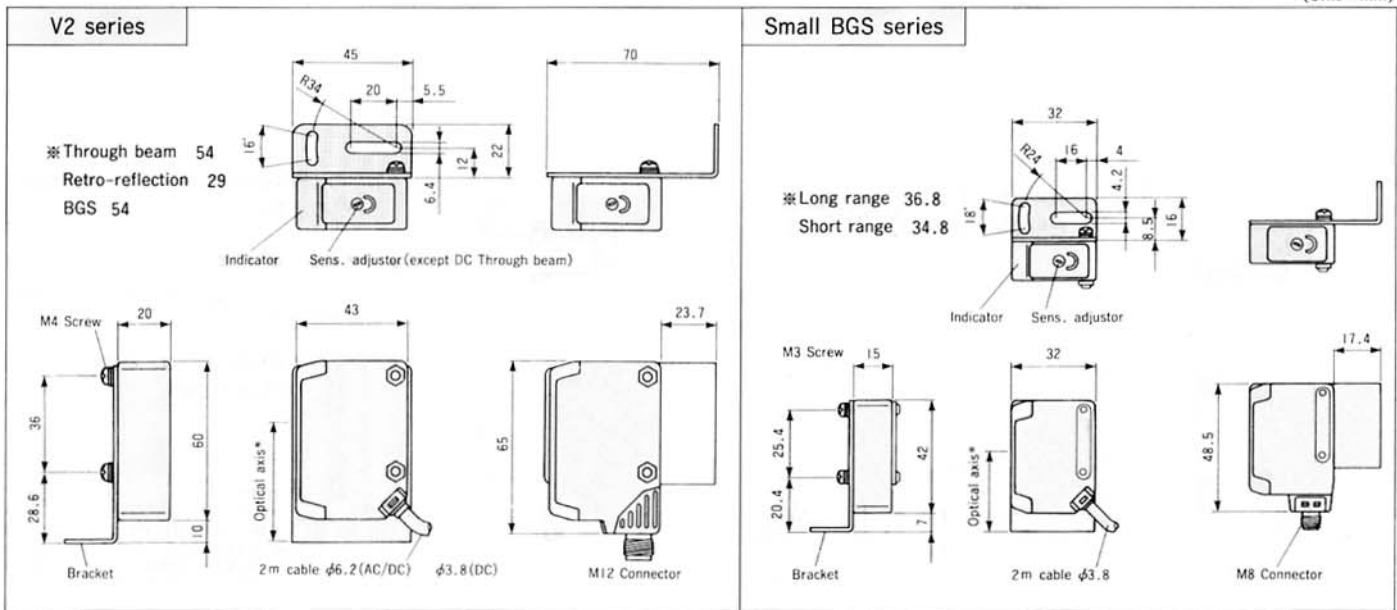

INPUT AND OUTPUT CIRCUIT DIAGRAMS

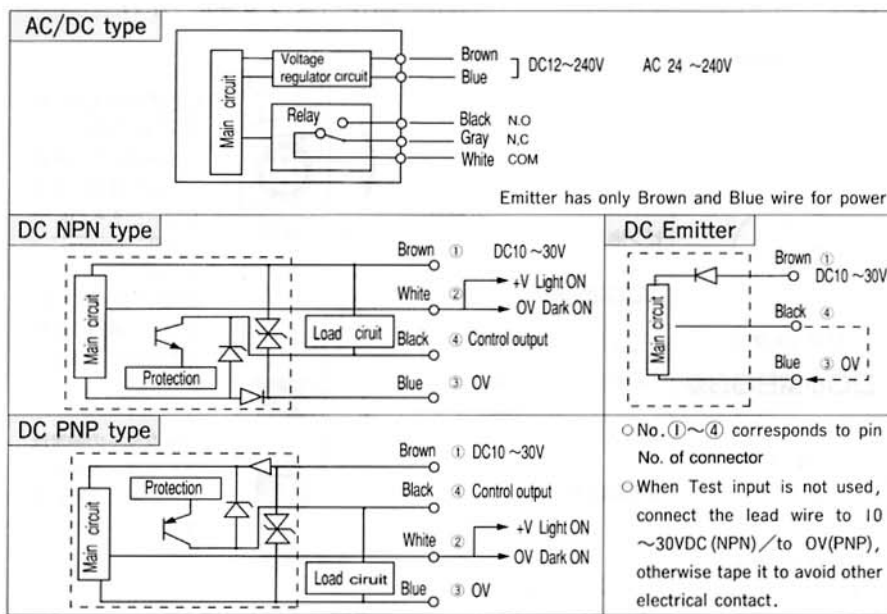

Accessories

- Standard reflection mirror Type V-61 (for Retro-reflection)

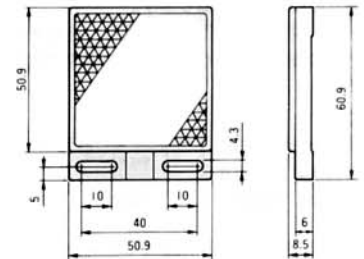

- Optional reflection mirror Type V-42

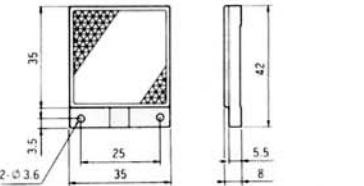

(Unit : mm)

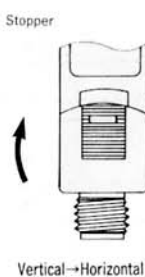
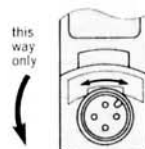
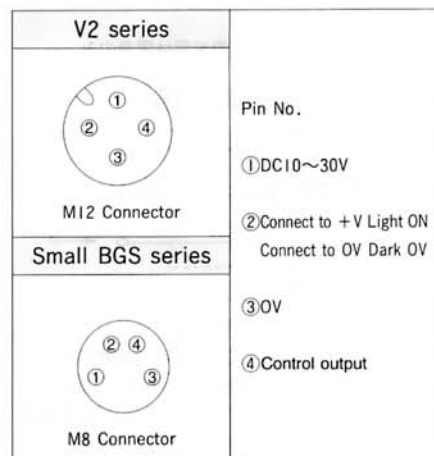

- Connectors are inter-changeable between horizontal and vertical mode.

Make sure to turn the connector as shown, otherwise you will damage the connector.

- Set up the stopper to fix the connector.

Developed by
• OPTEX CO., LTD.

Manufactured by
OPTEX

OPTEX CO., LTD.
 4-7-5 Nirohama Otsu 520-0801 Japan
 TEL:077524-6049 FAX:077524-3201 TELEX:5464852 OPTEX J
 2001.7.0531135

Optex-FA U.S. Sales
 Ramco Innovations
 (800) 280-6933
 www.optex-ramco.com